



QUALITY SINCE 1936



QUALITY SINCE 1936



FLORY 490 PTO HARVESTER

PO BOX 908
4737 TOOMES RD
SALIDA CA 95368
www.goflory.com

209-545-1167



QUALITY SINCE 1936

490 PTO HARVESTER

FEATURES

- Cost-effective harvesting for a variety of nut crops and conditions
- 48 In. straight-thru conveyance with 3 stage tumbling action provides maximum dirt separation for superior cleaning performance
- The proven pickup system combined with twin rod chains result in a much cleaner product
- 3 In. pick-up belt shaft for extended belt life
- Simple shaft and chain drive system reduce cost and ease serviceability

OPTIONS

- Auger Drive Kit
- Front Paddle Sweeps
- Hydraulic Power Pak
- Herbst Valve Kit
- Camera Kit with Monitor



TWIN-ROD CHAINS
 FOR ALMONDS AND HAZELNUTS.
 A VARIETY OF CHAINS ARE AVAILABLE
 FOR OTHER CROPS.

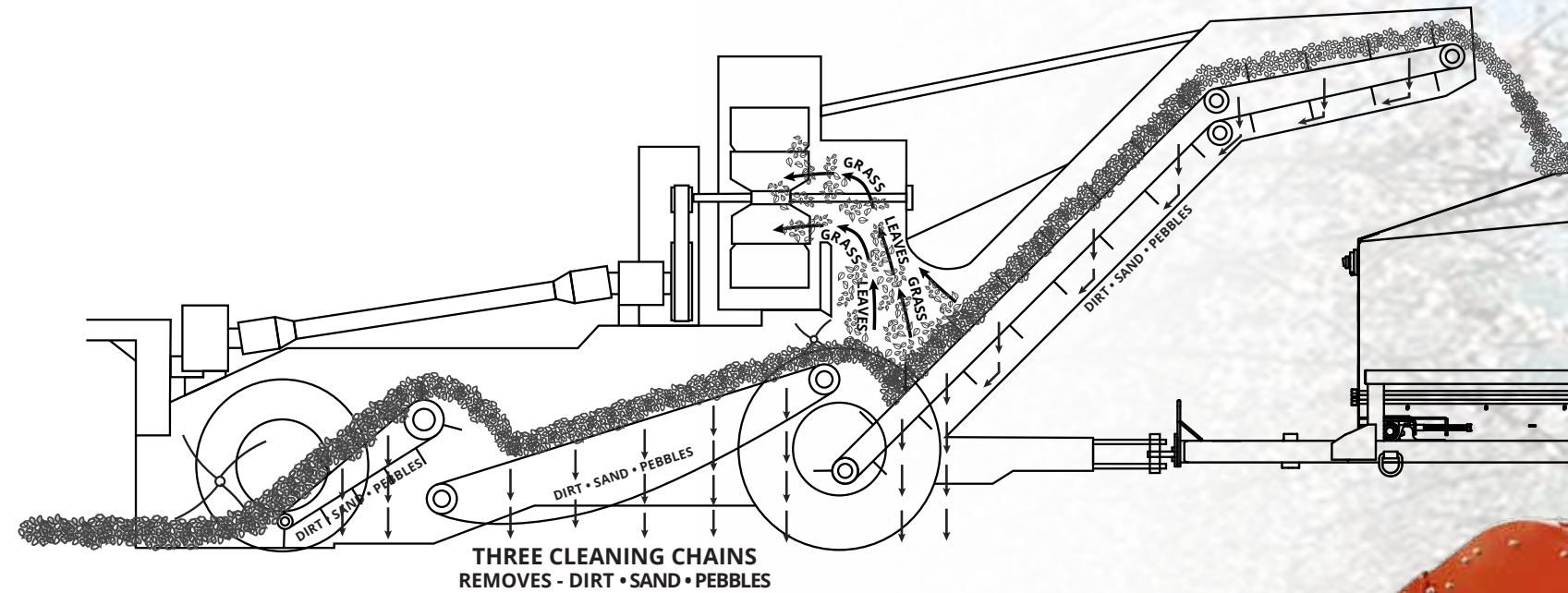

SPECIFICATIONS

PTO SPEED	540 RPM
MIN. PTO HP.	75 HP. - ALMONDS 85 HP. - WALNUTS 85 HP. - PECANS
FRONT TIRES	27 X 9.50 - 15, 4 PLY
REAR TIRES	31 X 13.50 - 15, 8 PLY
THROAT WIDTH	48 IN.
AUX PUMP FLOW	20 GPM
WEIGHT	6,400 LBS.



490 - PTO HARVESTER