



QUALITY SINCE 1936



QUALITY SINCE 1936

FLORY 860 LOW DUST PTO HARVESTER

PO BOX 908
4737 TOOMES RD
SALIDA CA 95368
www.goflory.com

209-545-1167





860 LOW DUST PTO HARVESTER

FEATURES

- High-capacity PTO powered nut harvester designed to maximize harvest speed, operational efficiency, and crop cleanliness
- Large, low-speed suction fan produces superior cleaning while decreasing dust emissions and wear
- Three twin rod cleaning chains for superior dirt separation
- Hydraulically driven pickup and conveying systems ensure dependability and smooth operation
- Easy change over from one type of crop to another
- Standard features include adjustable hydraulic hitch and hazard lights with turn signals

OPTIONS

- Auger Drive Kit
- Hydraulic Power Pak
- Front Paddle Sweeps (std. for pecans and hazelnuts)
- Mud Brush (std. for hazelnuts)
- Herbst Valve Kit
- Camera Kit with Monitor

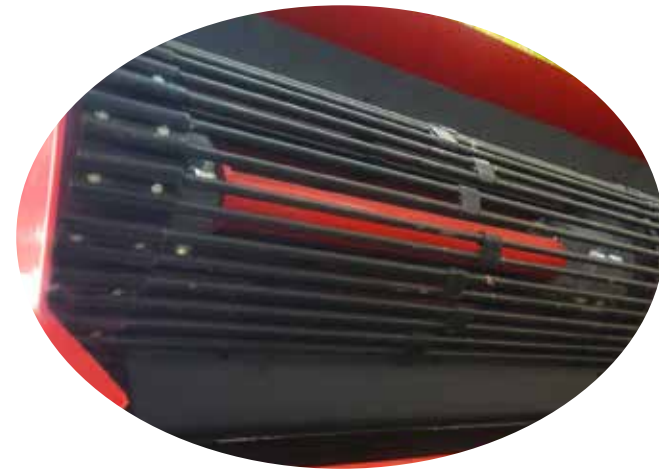

TWIN-ROD

ALMOND CHAINS AND A WIDE VARIETY OF CHAINS AVAILABLE FOR OTHER CROPS

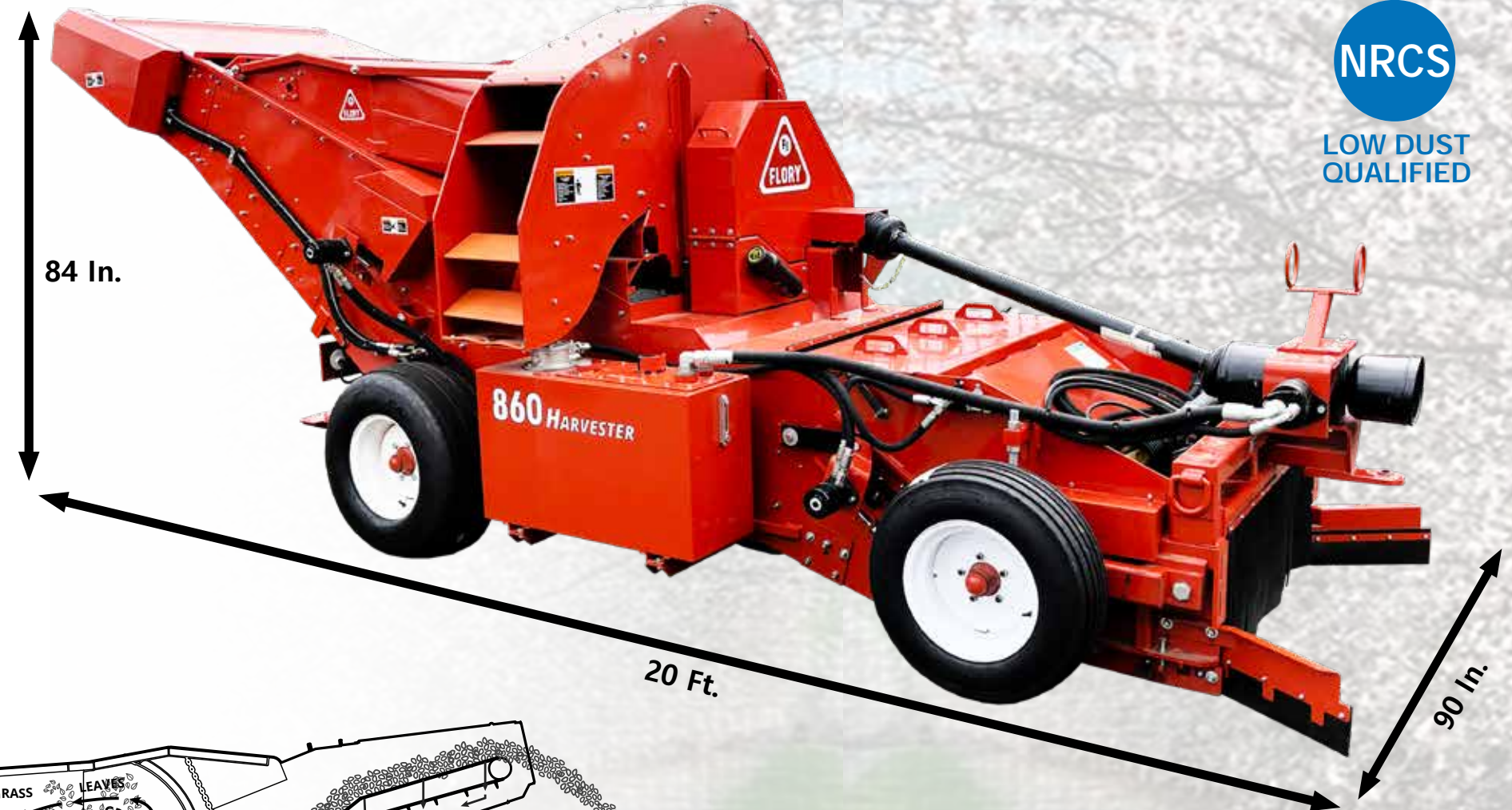
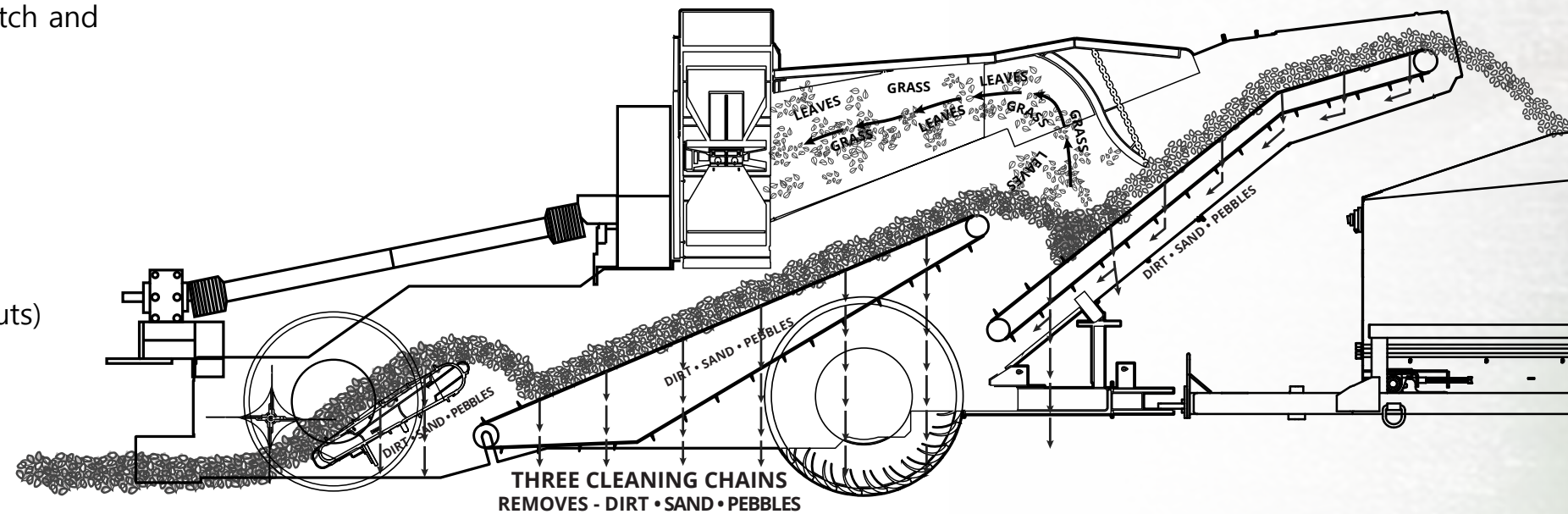

SPECIFICATIONS

HYDRAULIC OIL CAPACITY	40 GAL.
PTO SPEED	540 RPM
MIN. PTO HP.	85 HP.
FRONT TIRES	27 X 9.50 - 15, 4 PLY
REAR TIRES	31 X 13.50 - 15, 8 PLY
THROAT WIDTH	48 IN.
WEIGHT	7,300 LBS.