

VX240



CONVENTIONAL LOW DUST



VORTEX
CLEANING SYSTEM



QUALITY SINCE 1936

FLORY VX240
VORTEX ULTRA-LOW DUST
PTO HARVESTER

PO BOX 908
4737 TOOMES RD
SALIDA CA 95368
www.goflory.com

209-545-1167



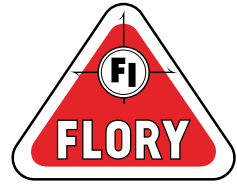

QUALITY SINCE 1936

VX240 - VORTEX ULTRA-LOW DUST PTO HARVESTER

FEATURES

- Ultra-low dust emissions that far surpass NRCS low dust standards without sacrificing harvest speed or crop cleanliness
- VORTEX Cleaning System delivers water-free dust suppression due to the innovative patent pending design
- Three twin rod cleaning chains for superior dirt separation
- Swivel gearbox allows for continuous PTO operation while turning
- Easy tool-free head height adjustment with jack mechanism
- Improved side plate wear strip and deflector adjustment
- Control screen in tractor with rear view camera system for maximum cart visibility

OPTIONS

- Front paddle sweeps



LOW DUST QUALIFIED



SPECIFICATIONS	
PTO SPEED	1,000 RPM
MIN. PTO HP.	75 HP.
HYDRAULIC OIL CAPACITY	50 GAL.
THROAT WIDTH	57 IN.
CONVEYANCE WIDTH	48 IN.
WEIGHT	10,280 LBS.
TIRES	FRONT: 280/70R-15 REAR: 385/65R-22.5

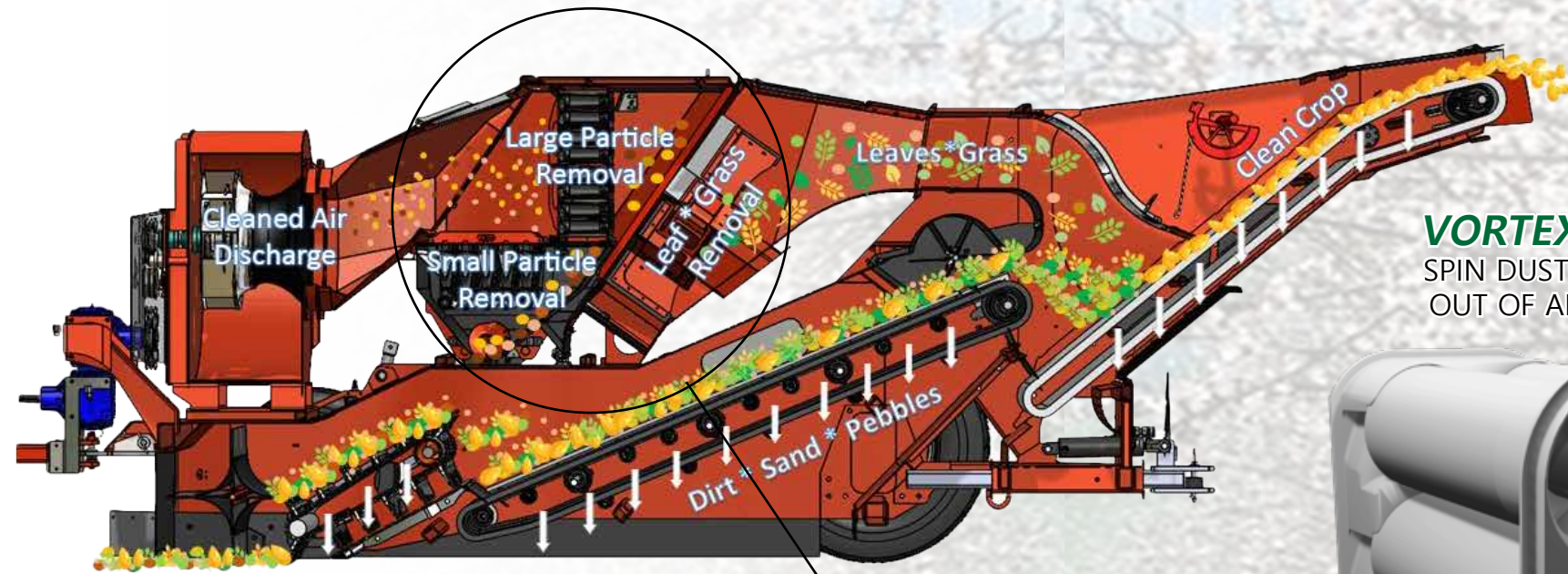

VORTEX TUBES
SPIN DUST PARTICLES
OUT OF AIR STREAM

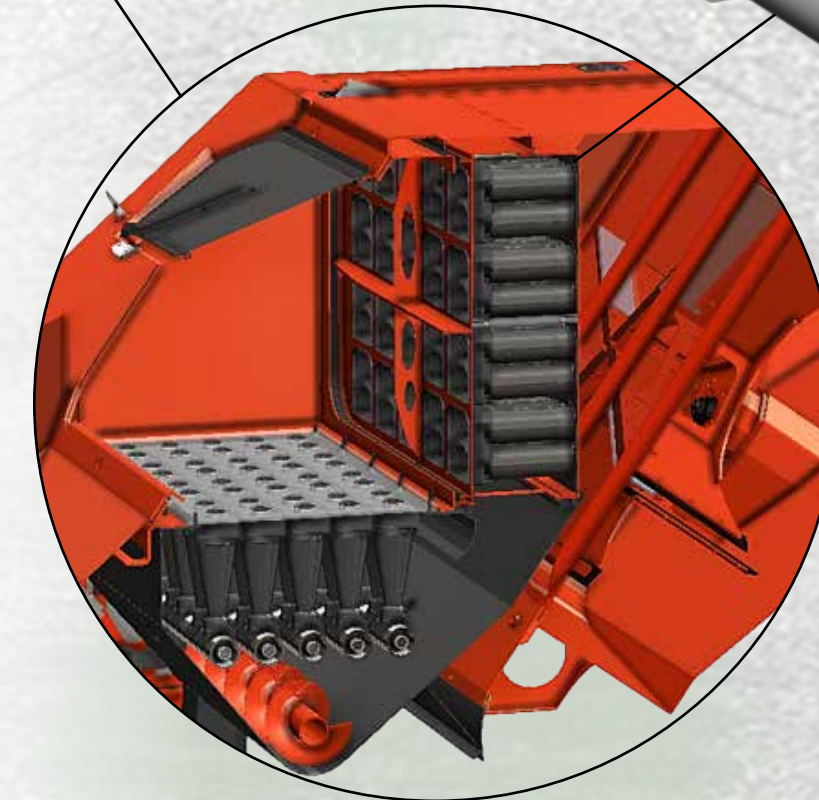
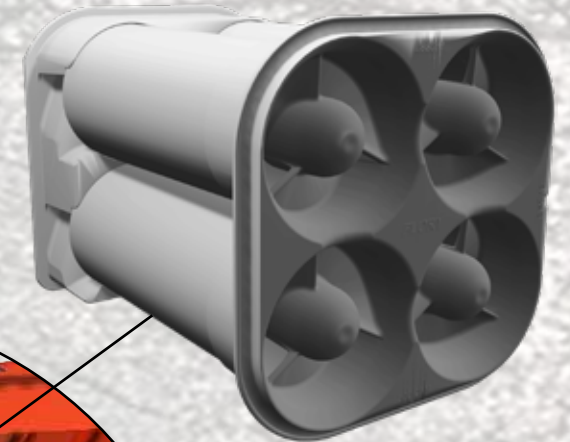

VORTEX
CLEANING SYSTEM

VX240 - VORTEX ULTRA-LOW DUST PTO HARVESTER